

# SL. Carborundum

(Thailand) company limited

## Our Factory



**SL. Carborundum (THAILAND) Co., Ltd.** is a specialized company in Thailand that primarily manufactures abrasive products. Since our establishment in 1973, we have provided wide range of grinding wheels which use in many applications and industries, such as cylindrical grinding, internal grinding, surface grinding, roller grinding, etc.

# SL. Carborundum

(Thailand) company limited

## Our Factory

Our grinding wheels are manufactured under ISO 9001: 2015 standard and are in complied to ANSI, JIS and FEPA standards. With experience of ATC abrasive consultant, Mr. Carlos Rocha, who have worked with Carborundum for more than 13 years, we have achieved fast growth in technical and business development. Our competitive edge tied with our sincerity and enthusiasm, which results in the continuous effort to boost the standard of our products and services to benefits our customers





# SL. Carborundum (Thailand) company limited

## Conventional method

- Mixture of diamond chip, glass chip, cement and salt flakes
- How to make: accrete molding then grind to the desirable shape



## Current method

- Contain Silicon carbide and ceramic mixture
- How to make: using mix grain of Silicon carbide, molding shape using pressing machine then undergo the firing process and finish off with the grinding



## New method

- Contain Synthetic diamond
- How to make: Using Nickel bonding from Electroplate technology



# SL. Carborundum (Thailand) company limited

How the rice whitener work



Rice whitener

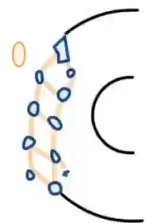

Self-sharpening

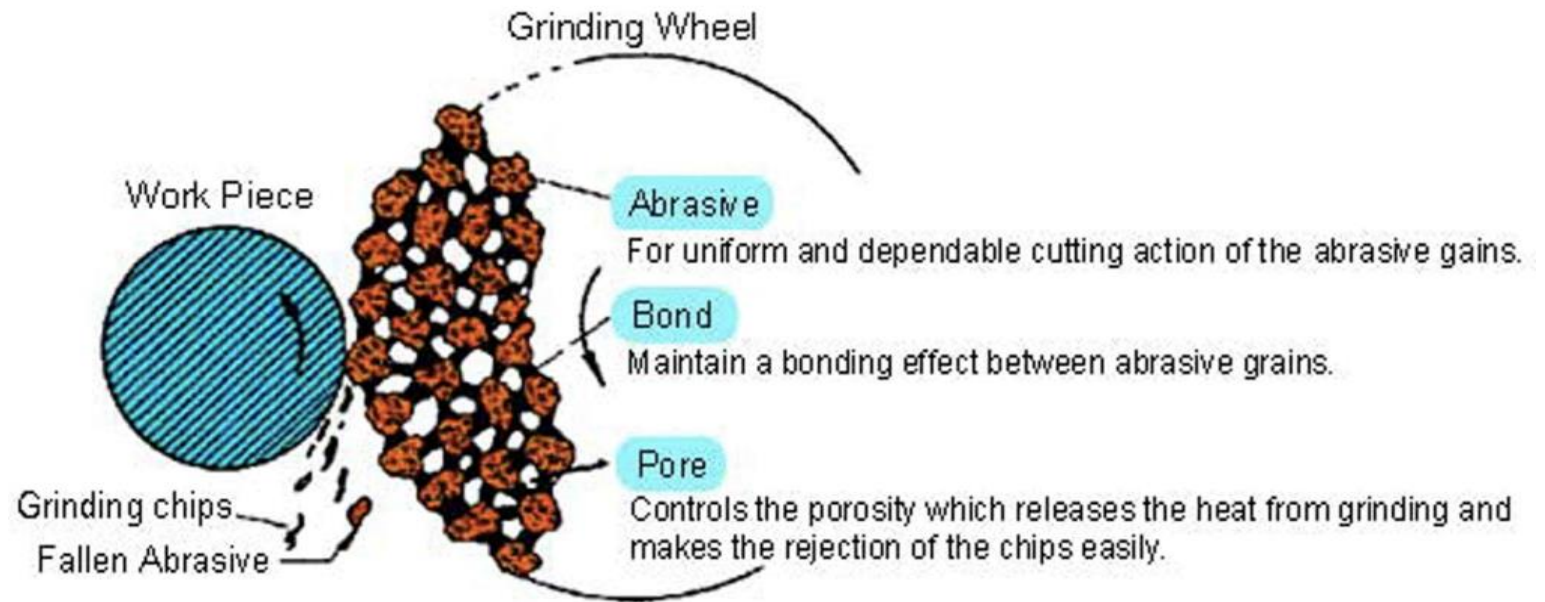

# SL. Carborundum

(Thailand) company limited

## Why we are the 1<sup>st</sup> choice of Rice whiteners

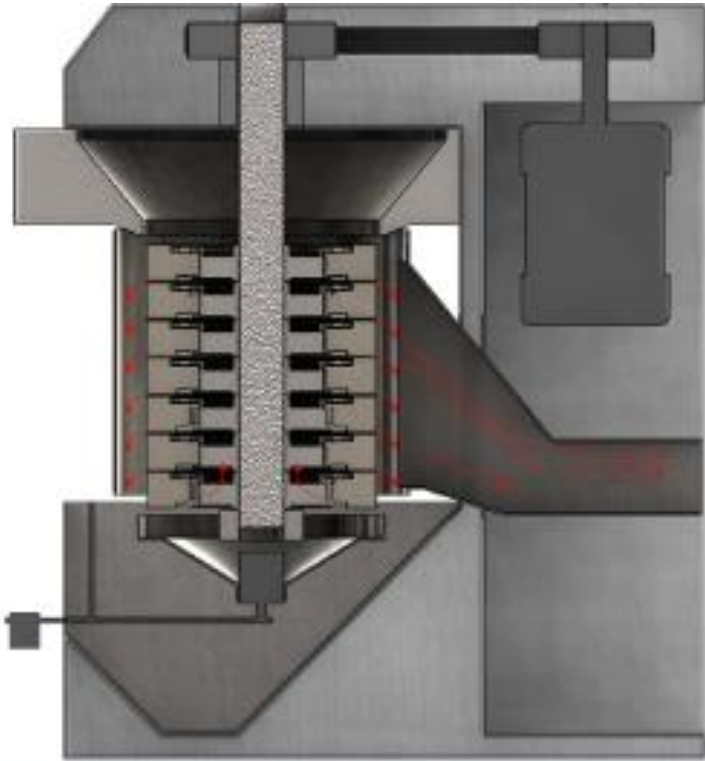

Our Rice whiteners design to meet :

Optimize milling Zone / Highly Milling yield and Fewer Broken

Save and non toxic with high quality of Ceramic coated

Safety operation at  $V_{max}$  35 m/s

- Tool life warranty: 4,000 hours



# SL. CARBORUNDUM RICE POLISHING STONE

Currently serving more than 500 rice mills  
Full service from our engineer team  
Support most of the global machine makers



- **SL-C : Conventional Machine**
- **SL-VT : Satake Machine**
- **SL-L : Buhler Machine**
- **SL-D : Desco Machine**
- **SL-R : Rice Machine**
- **SL-V : Vietnam Machine**



# SL. Carborundum (Thailand) company limited

## Synthetic Diamond



**Pass 1 # No.24**  
**Silicon Carbide**



**Pass 2 # No.24**  
**Silicon Carbide**



**Pass 3 # No.24**  
**Test**



**Pass 4 # No.30**  
**Silicon Carbide**



**Pass 5**  
**Normal Screen**



# SL. Carborundum

(Thailand) company limited

## DIAMOND RICE WHITENING WHEELS

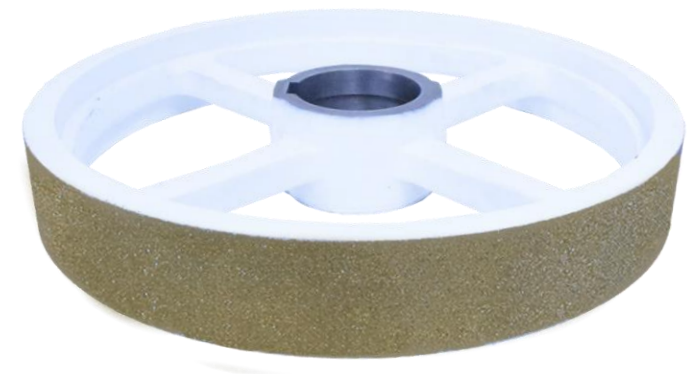



PRICE LIST							
หินสีข้าว KMC	สูง	ราคาเบอร์หิน เขียว/ชุด (บ.)	ราคาแกน เหล็ก/ชุด (บ.)	หินสีข้าว KMC	สูง	ราคาเบอร์หิน เขียว/ชุด (บ.)	ราคาแกน เหล็ก/ชุด (บ.)
				30/32	18"	91,900	41,500
14/16	16"	40,500	21,500		16"	81,500	41,500
16/18	16"	44,900	21,500	32/34	18"	105,900	47,500
18/20	16"	49,500	26,500		16"	93,500	47,500
20/22	18"	56,900	35,900	34/36	16"	102,500	47,500
	16"	53,500			18"	112,500	53,500
22/24	18"	60,900			19"	117,500	53,500
	16"	56,900			24"	137,900	59,500
24/26	18"	65,500			28"	155,500	64,900
	16"	58,900			40/42	16"	117,500
26/28	18"	68,500		18"		150,900	69,500
	16"	60,900		19-20"		162,500	69,500
28/30	18"	81,500		24"		215,900	72,500
	16"	68,500			30"	228,500	95,500

รายละเอียดเบอร์หินเขียว

GC#16 ,GC#24 ,GC#30 ,GC#36

หินทุกเบอร์ราคาเดียวกัน

- ระยะเวลาในการผลิต 90 วัน
- ราคาแกนเหล็กไม่รวมฝา
- ราคารวม vat 7%
- ราคา 1 ม.ค. 65

PRICE LIST							
หินสีข้าว KMC	สูง	ราคาเบอร์หิน ดำ/ชุด (บ.)	ราคาแกน เหล็ก/ชุด (บ.)	หินสีข้าว KMC	สูง	ราคาเบอร์หิน ดำ/ชุด (บ.)	ราคาแกน เหล็ก/ชุด (บ.)
14/16	16"	34,900	21,500	30/32	18"	83,500	41,500
16/18	16"	40,500	21,500		16"	74,500	41,500
18/20	16"	44,900	26,500	32/34	18"	96,500	47,500
20/22	18"	51,900	35,900		16"	84,900	47,500
	16"	48,500		34/36	16"	92,900	47,500
22/24	18"	55,500			18"	102,500	53,500
	16"	51,900			19"	106,900	53,500
24/26	18"	59,500			24"	125,500	59,500
	16"	53,500			28"	141,500	64,900
26/28	18"	62,500			40/42	16"	106,900
	16"	55,500		18"		136,500	69,500
28/30	18"	74,500		19-20"		147,900	69,500
	16"	62,500		24"		196,500	72,500
				30"		207,500	95,500

- ระยะเวลาในการผลิต 90 วัน
- ราคาแกนเหล็กไม่รวมฝา
- ราคารวม vat 7%
- ราคา 1 ม.ค. 65

รายละเอียดเบอร์หินดำ

C#16 ,C#24 ,C#30 ,C#36

หินทอเบอร์ด้าดำเดียวกับ



รุ่น	ขนาด D*T*H (มม.)	จำนวน (ก้อนต่อชุด)	ราคาสดำ (บาท/ชุด)	ราคาสดำ (บาท/ก้อน)	ราคาสีเขียว (บาท/ชุด)	ราคาสีเขียว (บาท/ก้อน)
SL-VT 20	(555x62x404)	9	80,100	8,900	89,100	9,900
SL-VT 15	(510x62x345)	9	62,100	6,900	72,900	8,100
SL-VT 12	(460x70x305)	9	55,800	6,200	69,300	7,700
SL-VT 10	(460x70x305)	7	43,400	6,200	53,900	7,700
SL-VT 5	(356x46x214)	9	31,500	3,500	40,500	4,500
SL-VT 7	(410x63x285)	7	31,500	4,500	38,500	5,500
SL-D-2500	(250x60x160)	5	17,500	3,500	19,500	3,900
SL-D-6000 (5pcs.)	(340x93x230)	5	28,333	5,667	35,000	7,000
SL-L	(340x95x230)	6	34,000	5,667	42,000	7,000
SL-D-6000 (6pcs.)	(340x93x230)	6	34,000	5,667	42,000	7,000
SL-D-9000	(454x110x310)	5	67,500	13,500	77,500	15,500
SL-I	(310x160x180)	5	47,500	9,500	52,500	10,500
SL-R 16 "	16"	3	34,500	11,500	46,500	15,500
SL-R	ใหญ่	6	95,400	15,900	105,000	17,500
SL-V		8	119,200	14,900	132,000	16,500

รายการ แกนหลัก	ชั้น/ชุด	ราคาขาย		ราคาหลังหัก ส่วนลด 10%	
		บาท/ชั้น	บาท/ชุด	บาท/ชั้น	บาท/ชุด
SL-VT 5	9	1,900	17,100	1,710	15,390
SL-VT 10	7	3,900	27,300	3,510	24,570
SL-VT 12	9	3,900	35,100	3,510	31,590
SL-VT 15	9	4,500	40,500	4,050	36,450
SL-VT 20	9	4,900	44,100	4,410	39,690
SL-R		-	49,500	-	-
SL-V 60		-	54,900	-	-
SL-Vเวียดนาม	8	8,900	71,200	8,010	64,080
SL-I	5	6,500	32,500	5,850	29,250

Update ครั้งที่	หัวข้อ	วันที่
1	ลดราคาแกนเหล็กSL-VT5	21/1/2020
2	2.1 เพิ่มราคาหินและแกนVT20	3/3/2020
	2.2 ยกเลิกการลดราคาแกน 25%	3/3/2020
3	3.1เพิ่มราคาแกนSL-VT10	25/11/2021
	3.2เพิ่มราคาแกนSL-VT12	25/11/2021
	3.3เพิ่มราคาแกนSL-VT15	25/11/2021
4	ปรับราคาหินใหม่10%	4/1/2022
	4.1ปรับราคาหินใหม่ทั้งหมดยกเว้นKVT-15,12,10	
	4.1ปรับราคาแกนใหม่ทั้งหมด	
	4.2แก้ไขส่วนลดKVT-15,12,10	

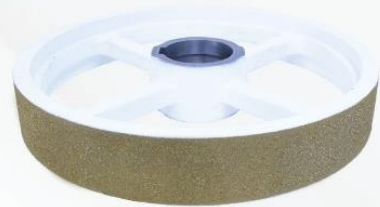
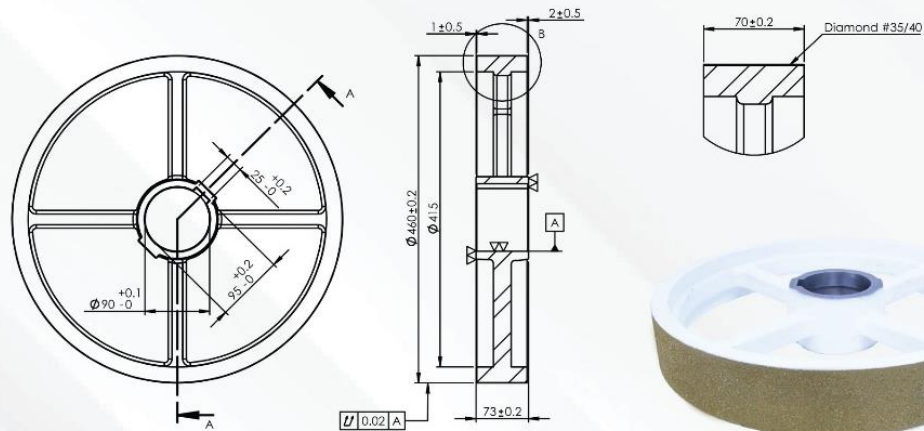

**(7Pcs. : 1 Set.)**

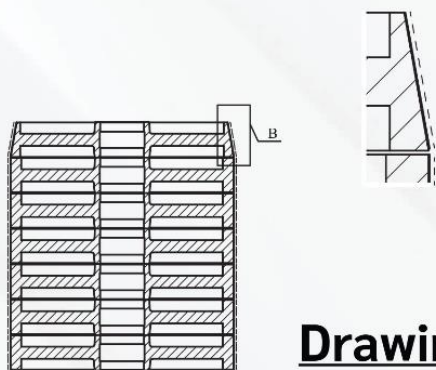

**Drawing**

# DIAMOND

## RICE WHITENING WHEELS

SPEC : SD30P(VTA-10) 460D-73T-71T1-90H ( 7 Pcs. )

SPEC : SD30P(VTA-12) 460D-73T-71T1-90H ( 9 Pcs. )

<b>7 Pcs.</b>	<b>250,000.-</b>
<b>9 Pcs.</b>	<b>320.000.-</b>



# SL. Carborundum

(Thailand) company limited

**The First choice of High  
performance of Grinding solution**

